



3 July 2023

ALTECH – CERENERGY® BATTERY PROJECT SUPPLIERS CONFIRMED

Highlights

- German battery plant suppliers selected
- Extensive expertise in manufacturing plants, automation and robotics
- Design basis completed of one battery cell unit every 45 seconds
- Outstanding progress and advancement of the project Definitive Feasibility Study
- Expert Workshops continue to advance the CERENERGY® battery project

Altech Batteries Limited (Altech/the Company) (ASX: ATC and FRA: A3Y) is pleased to provide an update on its CERENERGY® battery joint venture with Fraunhofer IKTS (“Fraunhofer”). There has been outstanding progress and advancement as the Company finalises the plant design with the various suppliers. Critical expert Workshops were held during the week commencing 22 May 2023 at Fraunhofer’s facility in Dresden, Germany.

The Workshops were attended by Altech personnel, Leadec’s process and automation engineering team, and Fraunhofer’s CERENERGY® expert battery team. Most importantly, all the key suppliers for the project attended the Workshops and presented their designs for their section of plant. All design areas involve high automation and robotics. The Workshops were headed and led by Managing Director Iggy Tan.



Figure 1 – Cerenergy Battery Project site layout in Saxony, Germany

Ceramic Mixing Systems

Altech is working with **Gustav Eirich GmbH** (Eirich), a highly experienced German company that provides advanced ceramic powder mixing and granulation equipment and technology. Eirich will also provide equipment and technology for granulating salt and nickel, essential for battery cathodes. Eirich has a strong reputation, having worked with Fraunhofer before, making them a trusted partner in Altech's battery plant.

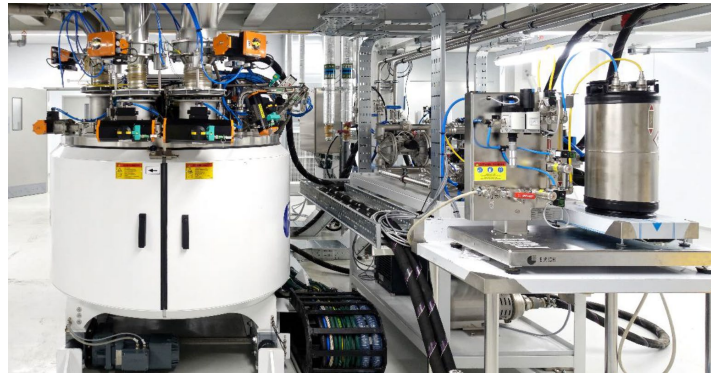

Figure 2 – Eirich ceramic mixing equipment and technology

Green Ceramic Cell Production

Frey Systeme GmbH (Frey) has been selected to provide isostatic machines for producing green ceramic tubes using alumina powder. Frey's advanced technology enables high-speed filling of rubber moulds and applies high pressure to produce green tubes. With robotic technology, this will achieve a remarkable production rate of one tube every 45 seconds.

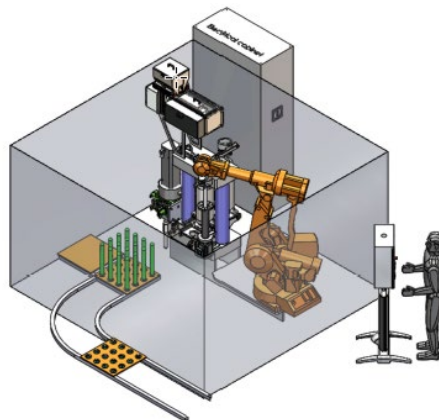

Figure 3 – Robotic isostatic pressing machine by Frey

Sintered Ceramic Cell Production

Altech has selected **Riedhammer GmbH** (Riedhammer), a world leading German ceramic kiln plant provider, who will provide a tunnel kiln for sintering of ceramic tubes, employing a heating profile of approximately 35 hours and maximum temperature of 1600°C. The Riedhammer tunnel kiln is designed to use renewable electricity for heating which will dramatically reduce the carbon footprint of the CERENERGY® battery.

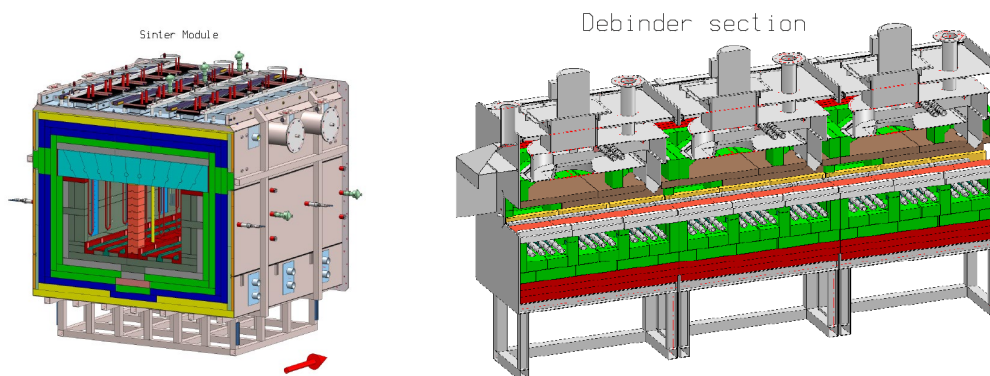

Figure 4 – Typical cross section of tunnel kiln technology utilising renewable power

Cell Quality Checks

Altech is working with **Xenon Automation GmbH** (Xenon) to implement comprehensive quality checks for completed sintered ceramic tubes, ensuring that there are no cracks or faults. Xenon's technology will involve optical and ultrasonic tests to detect faults. Additionally, Xenon has designed the initialisation process for completed cells, which involves subjecting them to a full charge and discharge cycle.

Cell Filling and Assembly

Fritz Automation GmbH (Fritz) has been chosen as the supplier for the cell assembly plant that encompasses various tasks such as tube cutting, ceramic ring assembly, ceramic to cell case assembly, electrode assembly and welding, cathode granules and medium filling, as well as cell and battery pack assembly. Fritz will also provide systems for cell initialisation and performance testing. Fritz have designed the advanced automation systems which will ensure efficient and precise execution of each step of the cell assembly process.

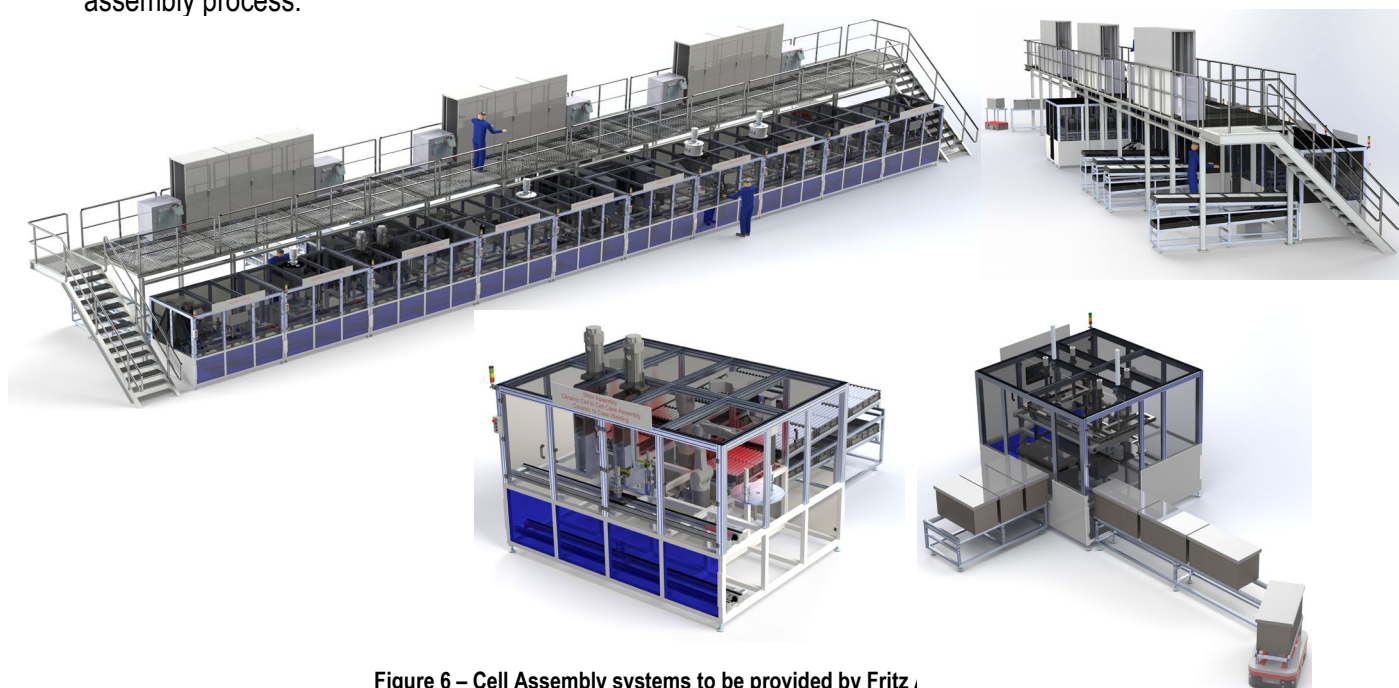

Figure 6 – Cell Assembly systems to be provided by Fritz

Battery Connections

Altech has selected **Hofer Powertrain GmbH** (Hofer), a leading German supplier of connector plates used for battery busbar connections and wire connections. Hofer's expertise lies in designing and manufacturing efficient and reliable solutions for battery cell mounting. With its advanced connector plate technology, Hofer Powertrain will help secure and seamless connections between battery cells.

Battery Casing

König Metall GmbH (König) has been chosen as the supplier for the insulated battery pack cases for the 60 KWh battery packs. These battery packs are designed with excellent vacuum insulation, ensuring that the exterior remains safe to touch. The cases are designed to IP 65 standards, which allow the batteries to operate in all weather conditions. The metal casings are designed for BMS and connector wiring at the bottom of each unit.

Cell Initialization

For the cell initialisation and subsequent performance testing of completed battery cells, **Dresden Elektronik GmbH** has been selected to provide automation and robotics around this manufacturing step. The unit is designed to efficiently collect test data and perform charge and full discharge cycles to ensure the proper functioning of the cells. Tracking each individual cell during the manufacturing process is critical to the proposed battery facility.

Battery Management Systems

Altech has partnered with **IAV GmbH Ingenieurgesellschaft Auto und Verkehr** (IAV) to provide an advanced Battery Management System (BMS) design for its 60 KWh battery pack and 1 MWh GridPack. The BMS allows seamless integration with site panel software control and enables remote operation when connected to customer grid control systems. It ensures optimal performance and safety of the battery packs and provides users with efficient management and monitoring capabilities. The proposed BMS design also offers remote control capabilities, optimising energy storage and utilisation based on real-time demand and supply dynamics.

1 MWh GridPack Iso-container

Altech has selected **Mein Lagerraum³ GmbH** for the fabrication of the specially designed iso-container frame to house the eighteen (18) 60 KWh battery packs that make up the 1 MWh GridPack (ABS 1000). The open style high cube sea container frame is specially designed for easy transport and simple site installation. The GridPacks will be assembled on the Altech site and then undergo a complete charge and discharge cycle before shipping to customers. These frames are being accredited for use.



Plant Electrics and Control Systems

Leadec Automation & Engineering GmbH (Leadec) has been appointed as the contractor to provide advanced electric and automation solutions for the battery plant. This will include intranet-equipped control centres and local operation systems, allowing for centralised monitoring and control of operations. In addition, a SCADA real-time live system, ensuring real-time data acquisition, visualisation, and control will be incorporated. Track and trace functionality along with batch identification will be the key feature of the battery plant.

Layout, Architecture and Permitting

Altech appointed **ARIKON Infrastruktur GmbH** (Arikon) to design and cost all site buildings and infrastructure on the CERENERGY® battery site. Arikon is the main contractor that will also manage the approval and permitting of the project with the local and state authorities. Additionally, Arikon is responsible for ensuring that site infrastructure meets all requirements for the construction, operation, and maintenance of the battery facility. Arikon was the infrastructure contractor for the Tesla Gigafactory in Brandenburg, Germany.

EPCM Contractor

Leadec Automation & Engineering GmbH (Leadec) has been chosen as the lead engineer for the Definitive Feasibility Study and possibly the EPCM contractor during the build of the CERENERGY® 100MWh Battery project. Leadec is a leading global service specialist for factories across the entire life cycle and related infrastructure. For 60 years, the German company has been supporting customers in the manufacturing industries; from planning, installation, and automation of the factories.

Managing Director Iggy Tan is extremely pleased with the progress of the CERENERGY® Battery Project and stated *"The level of excellence exhibited by the German plant unit suppliers we have brought together is truly remarkable. They possess extensive expertise in manufacturing plants that prioritise automation and robotics as essential components of the design. Our objective is to manufacture battery cells from the ground up, encompassing the production of ceramic solid-state tubes, full cell assembly, and conducting quality and battery performance checks at a rate of one every 45 seconds. We have made substantial progress in our design endeavours and are currently transitioning towards obtaining the final cost estimates for the plant. Given our exclusive rights to this technology, all our design efforts will pave the way for our future success"*.

Background

CERENERGY® batteries are the game-changing grid storage alternative to lithium-ion batteries. CERENERGY® batteries are fire and explosion-proof; have a life span of more than 15 years and operate in extreme cold and desert climates. The battery technology uses table salt and is lithium-free; cobalt-free; graphite-free; and copper-free, eliminating exposure to critical metal price rises and supply chain concerns. The Altech-Fraunhofer joint venture is developing a 100 MWh SCSS battery plant (Train 1) on Altech's land in Saxony, Germany, specifically focussed on the grid (stationary) energy storage market.

Since the CERENERGY® batteries can operate at a very wide temperature range of minus (-) 40 deg C to plus (+) 60 deg C, the battery pack will be ideal for the cold European climates. In addition, being fire-proof, the ABS60 battery packs will be safe to install indoors where lithium-ion batteries are prohibited.

The battery plant is being designed to produce ABS60 battery packs as a standard product to meet Europe's renewable energy and grid storage market. Fraunhofer have previously estimated that the cost of producing CERENERGY® batteries should be in the region of 40% cheaper than lithium-ion batteries, primarily due to not requiring lithium, graphite, copper or cobalt. This will be confirmed in the Definitive Feasibility Study that Altech is currently preparing.

Authorised by: Iggy Tan (Managing Director)

Altech Batteries Interactive Investor Hub

Engage with Altech directly by asking questions, watching video summaries and seeing what other shareholders have to say about this, as well as past announcements, at our Investor Hub <https://investorhub.altechgroup.com>

– end –

For more information, please contact:

Corporate

Iggy Tan

Managing Director
Altech Batteries Limited
Tel: +61 8 6168 1555
Email: info@altechgroup.com

Martin Stein

CFO & Company Secretary
Altech Batteries Limited
Tel: +61 8 6168 1555
Email: info@altechgroup.com

About Altech Batteries Ltd (ASX:ATC) (FRA:A3Y)

CERENERGY® Batteries Project

Altech Batteries Ltd is a specialty battery technology company that has a joint venture agreement with world leading German battery institute Fraunhofer IKTS ("Fraunhofer") to commercialise the revolutionary CERENERGY® Sodium Alumina Solid State (SAS) Battery. CERENERGY® batteries are the game-changing alternative to lithium-ion batteries. CERENERGY® batteries are fire and explosion-proof; have a life span of more than 15 years and operate in extreme cold and desert climates. The battery technology uses table salt and is lithium-free; cobalt-free; graphite-free; and copper-free, eliminating exposure to critical metal price rises and supply chain concerns.

The joint venture is commercialising its CERENERGY® battery, with plans to construct a 100MWh production facility on Altech's land in Saxony, Germany. The facility intends to produce CERENERGY® battery modules to provide grid storage solutions to the market.



Silumina Anodes™ Battery Materials Project

Altech Batteries has licenced its proprietary high purity alumina coating technology to 75% owned subsidiary Altech Industries Germany GmbH (AIG), which has commenced a definitive feasibility study for the development of a 10,000tpa silicon/graphite alumina coating plant in the state of Saxony, Germany to supply its Silumina Anodes™ product to the burgeoning European electric vehicle market.

This Company recently announced its game changing technology of incorporating high-capacity silicon into lithium-ion batteries. Through in house R&D, the Company has cracked the "silicon code" and successfully achieved a 30% higher energy battery with improved cyclability or battery life. Higher density batteries result in smaller, lighter batteries and substantially less greenhouse gases, and is the future for the EV market. The Company's proprietary silicon graphite product is registered as Silumina Anodes™.

The Company is in the race to get its patented technology to market, and recently announced the results of a preliminary feasibility study (PFS) for the construction of a 10,000tpa Silumina Anode™ material plant at AIG's 14-hectare industrial site within the Schwarze Pumpe Industrial Park in Saxony, Germany. The European graphite and silicon feedstock supply partners for this plant will be SGL Carbon and Ferroglobe. The project has also received green accreditation from the independent Norwegian Centre of International Climate and Environmental Research (CICERO). To support the development, AIG has commenced construction of a pilot plant adjacent to the proposed project site to allow the qualification process for its Silumina Anodes™ product. AIG has executed NDAs with two German automakers as well as a European based battery company.



HPA Production Project

Altech is also further aiming to become a supplier of 99.99% (4N) high purity alumina (Al₂O₃) through the construction and operation of a 4,500tpa high purity alumina (HPA) processing plant at Johor, Malaysia, and has finalised Stage 1 and Stage 2 construction of its HPA plant in Johor, Malaysia. Feedstock for the plant will be sourced from the Company's 100%-owned near surface kaolin deposit at Meckering, Western Australia and shipped to Malaysia. The HPA project is significantly de-risked with a bankable feasibility study completed, senior lender project finance from German government owned KfW IPEX-Bank approved, and a German EPC contractor appointed – with initial construction works at the site completed. In addition to the senior debt, conservative (bank case) cash flow modelling of the HPA plant shows a pre-tax net present value of USD 505.6million at a discount rate of 7.5%. The project generates annual average net free cash of ~USD76million at full production. Altech is in the final stages of project finance with a potential raising of US\$100m of secondary debt via the listed green bond market. In addition, US\$100m of project equity is being sought through potential project joint venture partners.